

# ACE-SDX

## Advanced Microstep Driver



---

COPYRIGHT © 2015 ARCUS,  
ALL RIGHTS RESERVED

First edition, September 2007

ARCUS TECHNOLOGY copyrights this document. You may not reproduce or translate into any language in any form and means any part of this publication without the written permission from ARCUS.

ARCUS makes no representations or warranties regarding the content of this document. We reserve the right to revise this document any time without notice and obligation.

**Revision History:**

- 2.0 – 1<sup>st</sup> Release
- 2.5 – 2<sup>nd</sup> Release
- 2.6 – 3<sup>rd</sup> Release
- 2.7 – 4<sup>th</sup> Release
- 2.8 – 5<sup>th</sup> Release

**Firmware Compatibility:**

†V200

†If your module's firmware version number is less than the listed value, contact Arcus for the appropriate documentation. Arcus reserves the right to change the firmware without notice.

# Table of Contents

<b>1. INTRODUCTION</b> .....	<b>4</b>
1.1. FEATURES .....	4
<b>2. ELECTRICAL AND THERMAL SPECIFICATIONS</b> .....	<b>5</b>
<b>3. DIMENSIONS</b> .....	<b>6</b>
<b>4. CONNECTIVITY</b> .....	<b>7</b>
4.1. 2-PIN POWER CONNECTOR (5.08MM) .....	7
4.2 4-PIN MOTOR CONNECTOR (5.08MM) .....	7
4.3 8-PIN MOTION IO CONNECTOR .....	8
4.4. ACE-SDX INTERFACE CIRCUIT .....	9
4.4.1. <i>Pulse/Dir (CW/CCW) Inputs</i> .....	9
4.4.2. <i>Enable Input</i> .....	11
4.4.3. <i>Alarm Output</i> .....	12
4.4.4. <i>Motor Connection</i> .....	13
<b>5. GENERAL SPECIFICATION</b> .....	<b>14</b>
5.1. MICROSTEP .....	14
5.2. CURRENT CONTROL .....	14
5.3. OVER TEMPERATURE ALARM .....	14
<b>6. DRIVER CONFIGURATION</b> .....	<b>16</b>
6.1. CONNECTIONS .....	16
6.2. SOFTWARE .....	16
6.3. DEFAULT SETTINGS .....	17

---

## 1. Introduction

ACE-SDX is a step motor driver with the following features:

### 1.1. Features

- 12-48V DC voltage input
- 100mA to 3.0A peak current setting
- Configurable Microstep setting of any value from 2 to 500
- One clock (Pulse/Dir) or Two clock (CW/CCW) support
- 1M maximum pulse rate support
- Opto-isolated differential Pulse/Dir (CW/CCW) inputs
- Opto-isolated driver enable input
- Opto-isolated over-temperature alarm output

For technical support contact: [support@arcus-technology.com](mailto:support@arcus-technology.com).  
Or, contact your local distributor for technical support.

## 2. Electrical and Thermal Specifications

Parameter	Min	Max	Units
Main Power Input <sub>1</sub>	+12	+48	V
	-	3.0	A
Forward Diode Current (PUL/DIR)	-	25	mA
Forward Diode Current (ENABLE)	-	40	mA
Operating Temperature <sub>2</sub>	-20	85	°C
Storage Temperature <sub>2</sub>	-55	150	°C

Table 2.0

<sub>1</sub>The supply current should match the driver current setting.

<sub>2</sub> Based on component ratings.

### 3. Dimensions

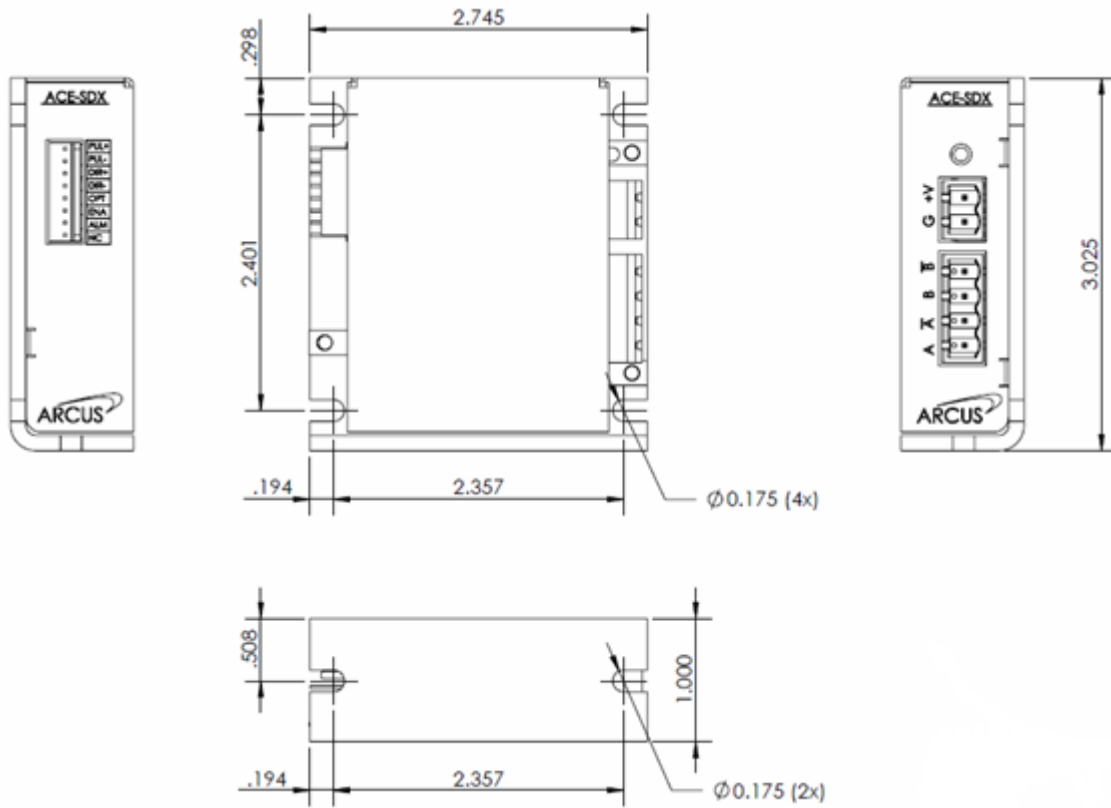

Figure 3.0

## 4. Connectivity

In order for ACE-SDX to operate, it must be supplied with +12VDC to +24VDC. Power pins as well as pin outs are shown below.

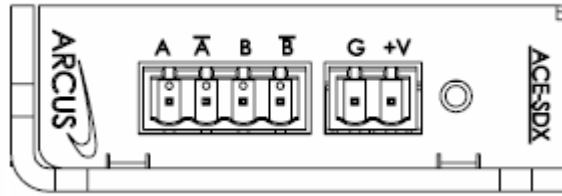

Figure 4.0

### 4.1. 2-Pin Power Connector (5.08mm)

Pin #	Name	In/Out	Description
1	G	I	Ground
2	V+	I	Power Input +12 to +48VDC

Table 4.0

Mating Connector Description: 2 pin 0.2" (5.08mm) connector  
 Mating Connector Manufacturer: On-Shore †  
 Mating Connector Manufacturer Part: EDZ950/2

† Other 5.08 mm compatible connectors can be use

### 4.2 4-Pin Motor Connector (5.08mm)

Pin #	Name	In/Out	Description
1	A	O	Phase A of Bi-polar Step Motor
2	/A	O	Phase /A of Bi-polar Step Motor
3	B	O	Phase B of Bi-polar Step Motor
4	/B	O	Phase /B of Bi-polar Step Motor

Table 4.1

Mating Connector Description: 4 pin 0.2" (5.08mm) connector  
 Mating Connector Manufacturer: On-Shore †  
 Mating Connector Manufacturer Part: EDZ950/4

† Other 5.08 mm compatible connectors can be used

**Important Note:** Do not disconnect the motor wires or motor connector while the power is on. Make sure to turn off the power when disconnecting the motor from the driver. Plugging or unplugging the motor while the power is on may damage the motor.

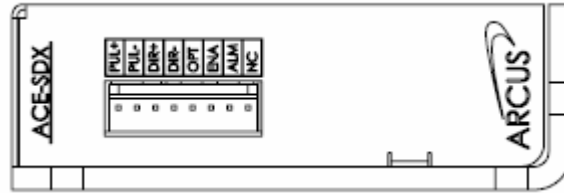

Figure 4.1

### 4.3 8-Pin Motion IO Connector

Pin #	Name	In/Out	Description
1	NC	NC	No Connection
2	ALM	O	Alarm Opto-isolated Output
3	ENA	I	Enable Opt-isolated Input
4	OPT	I	Opto-Supply Input (+5V)
5	DIR-	I	Dir- (CCW-) Opto-isolated Input
6	DIR+	I	Dir+ (CCW+) Opto-isolated Input
7	PUL-	I	Pulse- (CW-) Opto-isolated Input
8	PUL+	I	Pulse+ (CW+) Opto-isolated Input

Table 4.2

Mating Connector Description: 8 pin 0.1" (2.54mm) connector  
 Mating Connector Manufacturer: AMP  
 Mating Connector Housing Part Number: 770602-8  
 Mating Connector Pin Part Number: 770666-1



## 4.4. ACE-SDX Interface Circuit

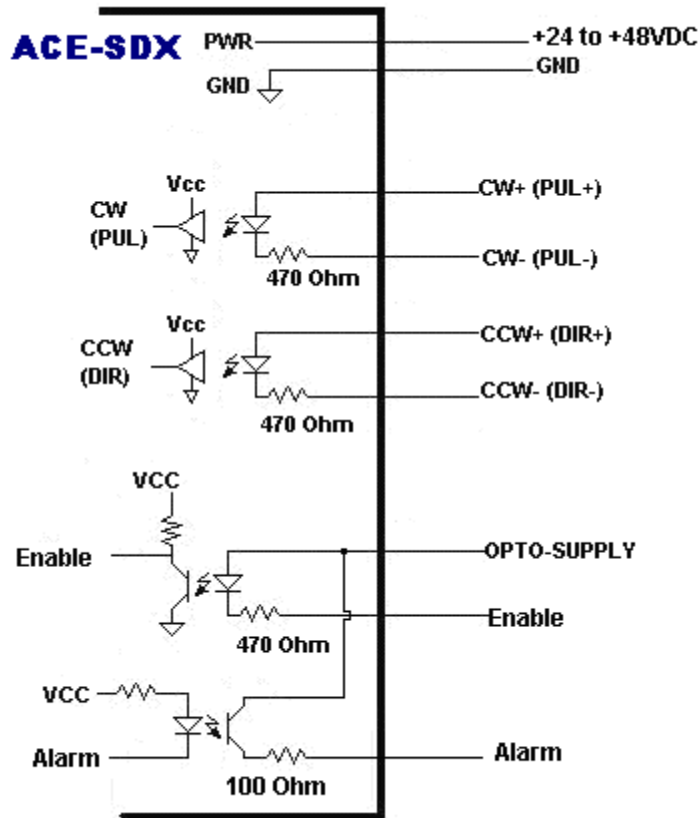

Figure 4.2

**Important Note:** The recommended opto-supply voltage is 5V. An additional current limiting resistor is required to support larger voltages.

### 4.4.1. Pulse/Dir (CW/CCW) Inputs

ACE-SDX supports both one-clock (Pulse/Dir) or two-clock (CW/CCW) inputs. One-clock uses Pulse signal as the amount of movement and Dir signal as the direction of the movement.

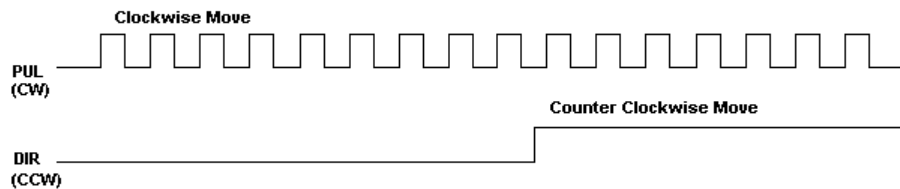

Figure 4.3

Two-clock uses CW as clockwise movement and CCW as counter clockwise movement.

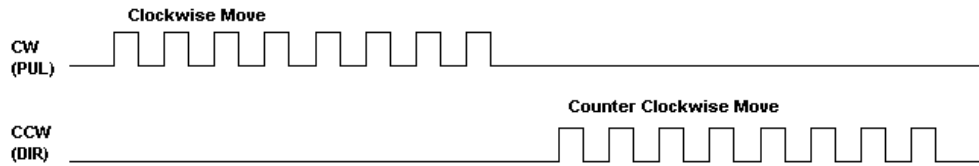

Figure 4.4

Depending on the direction polarity setting, actual direction of the stepper motor rotation can be configured for the application.

Maximum pulse rate support is 1M pulses/second.

Pulse/Dir (CW/CCW) inputs are opto-isolated differential inputs with 470 Ohm resistor as shown below. Maximum source current for the diode is 50mA. If voltage across is greater than 5V, make sure to add current limiting resistor to limit the current to 50mA across the diode. Figure 4.5 shows the detailed schematic of the opto-isolated pulse and direction inputs.

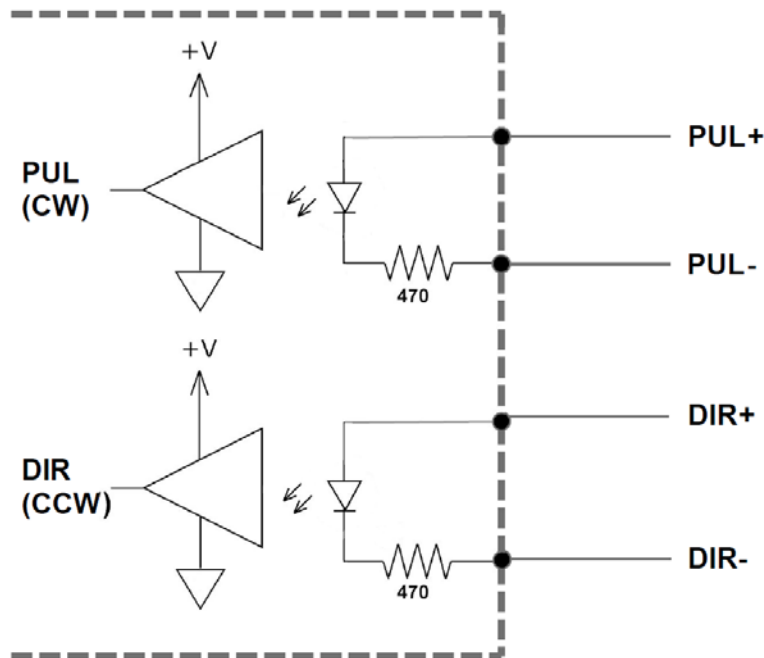

Figure 4.5

Figure 4.6 shows an example of wiring the pulse and direction inputs with a differential output.

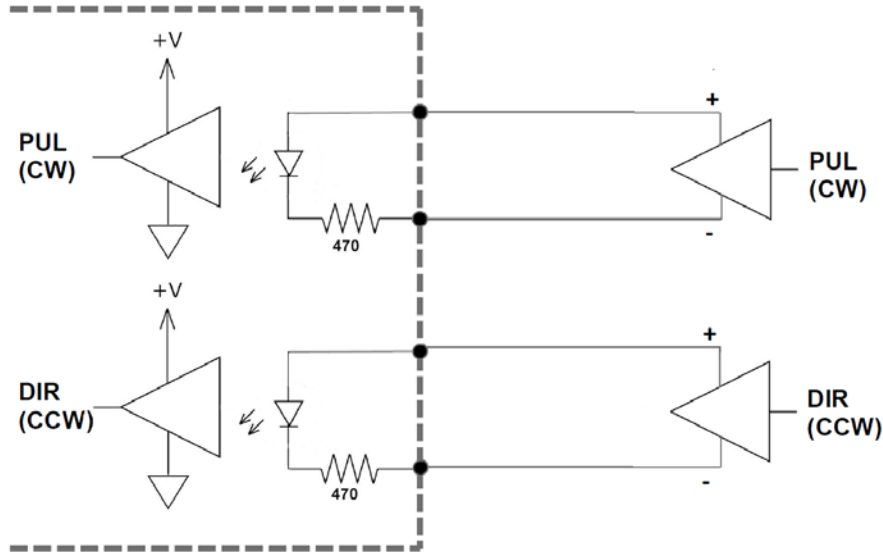

Figure 4.6

Figure 4.7 shows an example of wiring the pulse and direction inputs with an open-collector output.

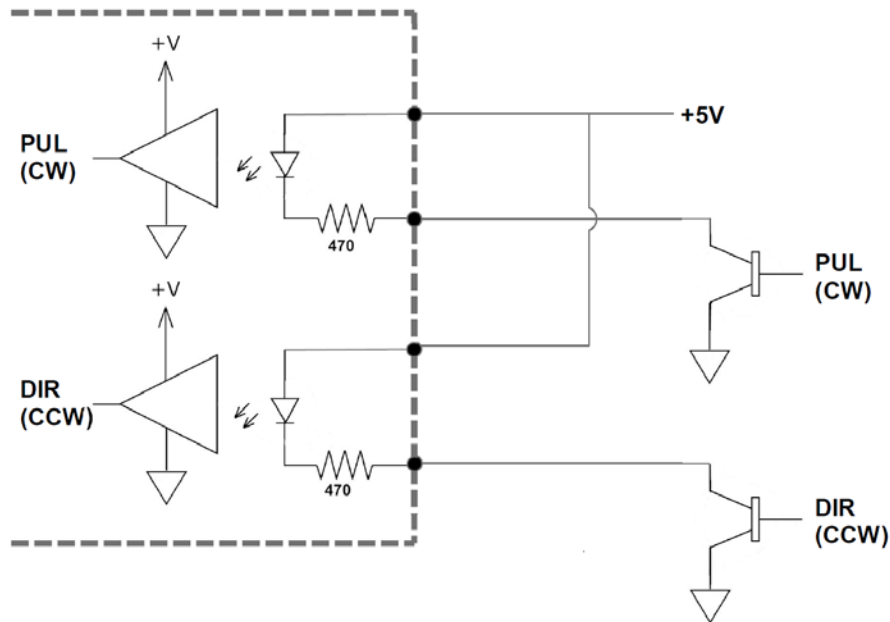

Figure 4.7

#### 4.4.2. Enable Input

Enable signal is an opto-isolated input. If there is no connection to the enable signal, the driver is enabled by default. Only when the enable signal is connected to the ground of the opto-supply input, the driver is disabled and motor

is free to rotate manually. Maximum source current for the diode is 50mA. If voltage other than 5V is used for the opto-supply, make sure to add current limiting resistor to limit the current to 50mA. Figure 4.8 shows the detailed schematic of the opto-isolated enable input.

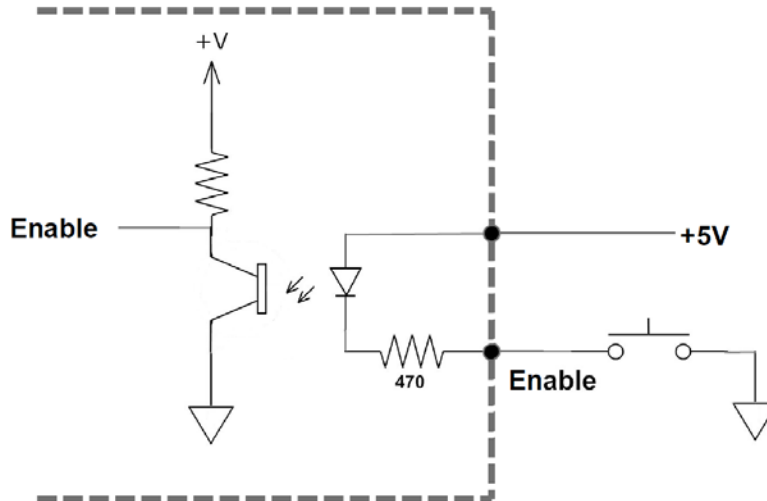

Figure 4.8

#### 4.4.3. Alarm Output

Alarm output is an opto-isolated output with 100 Ohm resistor. Maximum source current of the alarm output signal is 40 mA. Figure 4.9 shows a wiring example of the opto-isolated alarm output.

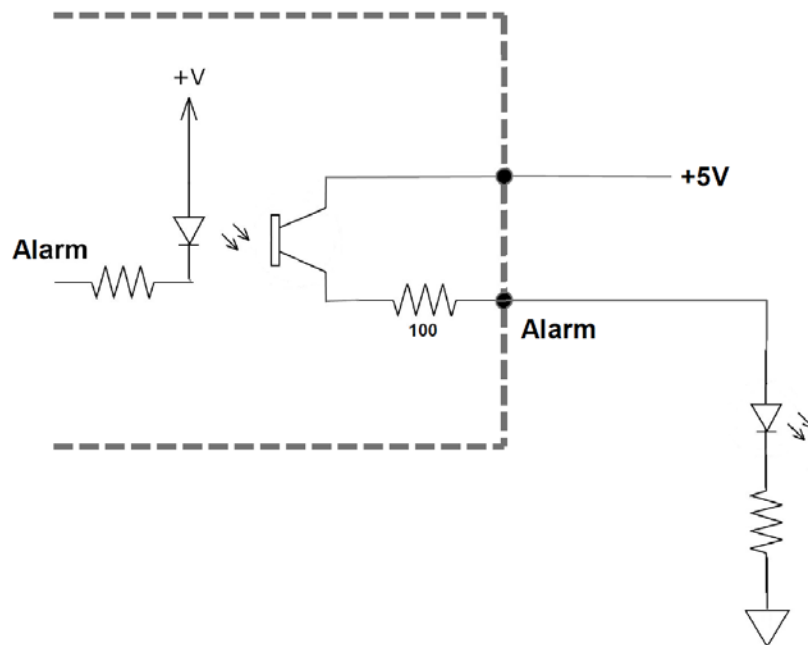

Figure 4.9

#### 4.4.4. Motor Connection

Connect the stepper 4-wire stepper motor to the ACE-SDX as shown in Figure 4.10

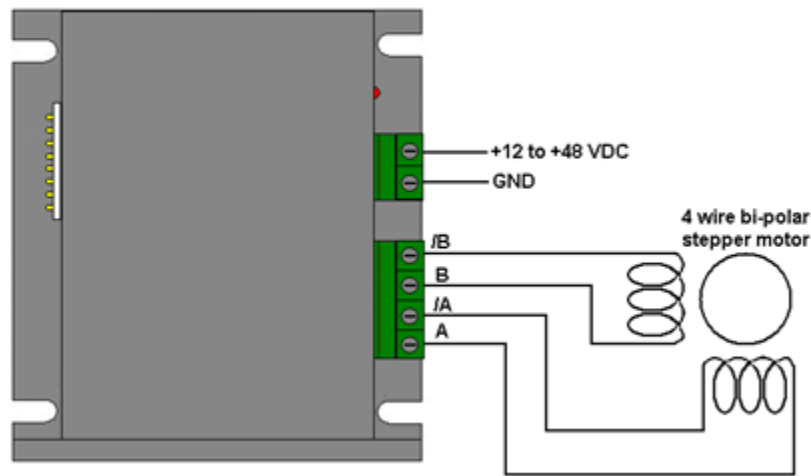

Figure 4.10

**Important Note:** Do not disconnect the motor wires or motor connector while the power is on. Make sure to turn off the power when disconnecting the motor from the driver. Plugging or unplugging the motor while the power is on may damage the motor.

---

## 5. General Specification

### 5.1. Microstep

Typical stepper motors are either 1.8 degrees per full step (200 full steps per revolution) or 0.9 degrees per full step (400 full steps per revolution). These steps can be divided with microstepping to increase position resolution. The ACE-SDX has a configurable microstep setting range from 2 to 500 microsteps.

### 5.2. Current Control

The ACE-SDX will have a maximum rated driver current that is dependent on the specification of the motor.

Setting the driver current higher than the maximum rated current will overheat the motor and driver and potentially damage the unit. It is recommended to use a current setting that is in the range of 60-80% of the maximum rated current for the motor.

ACE-SDX has configurable current setting from 100mA to 3.0A. Driver current is set to the “Run Current” setting whenever the motor is moving. Similarly, the driver current is set to the “Idle Current” setting when the motor is idle for a period of time longer than the “Idle Time” setting. See section 6.2 for more details regarding the available driver settings.

In order to reduce the risk of overheating, it is recommended to keep the current setting under 2.5 A for high duty cycle applications. In order to use the motor at currents higher than 2.5A, be sure that there is ample time for the motor to cool down after each use. Continuous usage at a high current setting may lead to damage of the driver or motor.

### 5.3. Over Temperature Alarm

ACE-SDX has a temperature sensor to detect over heating of the driver. Temperature sensing is done only when the driver is enabled. When the temperature goes over the over-temperature alarm value of 70°C, the Alarm Output is turned on. If the temperature goes below 68°C, the Alarm Output is turned off. If the temperature goes over 75°C, the driver is automatically turned off and will remain off until the temperature goes below 68°C. See Figure 5.0 below for a graphical representation of the over-temperature alarm function.

For details on wiring the alarm output, see Figure 4.9.

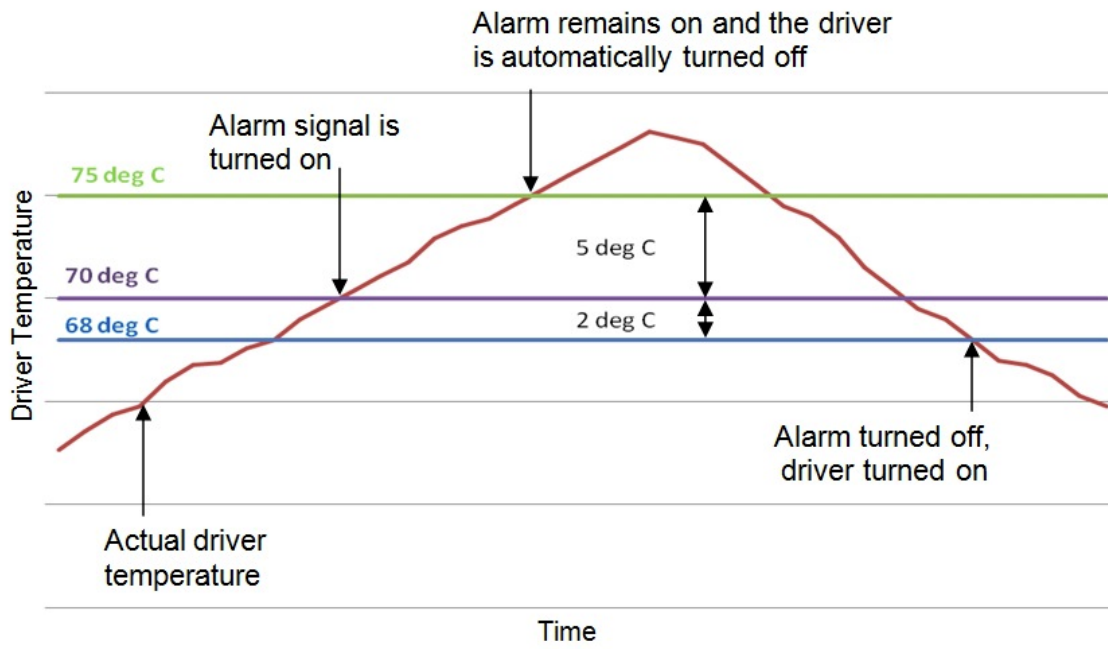

Figure 5.0

## 6. Driver Configuration

Following are ACE-SDX parameters that can be configured:

1. Microstep Setting: 2 to 500
2. Run Current: 100mA to 3.0A (peak current)
3. Idle Current: 100mA to 3.0A (peak current)
4. Idle Time: 100 msec to 10 sec
5. Direction Polarity
6. One-clock or Two-clock mode

ACE-SDX uses patent-pending Dynamic Configuration Method to read and write the driver parameters using the control signals (Pulse, Dir, Enable, and Alarm) of the driver. Dynamic Configuration eliminates the need for jumpers, switches, resistors, potentiometers or communication ports for reading and setting the driver parameters which result in a simple and cost-effective device.

### 6.1. Connections

The DMX-CFG-USB-ACE cable is used to configure the ACE-SDX. See Figure 6.0 to see how the configuration cable is connected to the ACE-SDX.

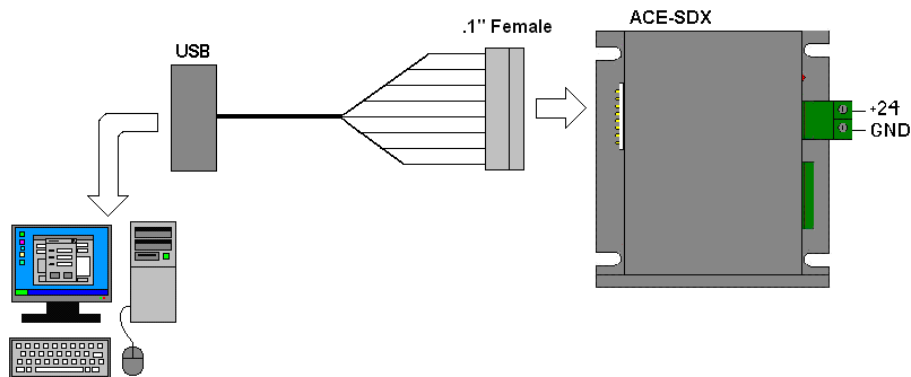

Figure 6.0

### 6.2. Software

Make sure that the USB driver is installed properly before running the controller.

See the DMX-CFG-USB-ACE Cables manual for details on configuration. Figure 6.1 shows the configuration interface.



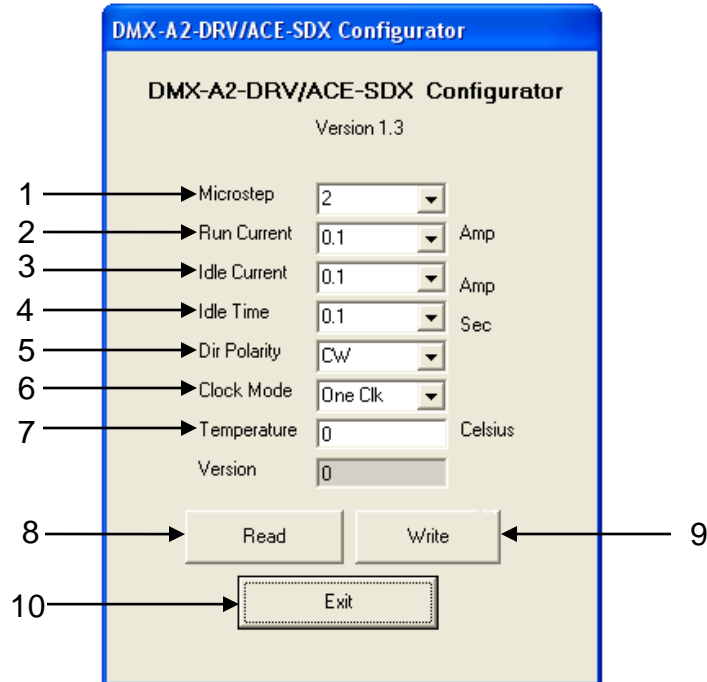

Figure 6.1

1. **Microstep Setting:** 2 to 500 microstepping.
2. **Run Current:** 100mA to 3.0A peak current.
3. **Idle Current:** 100mA to 3.0A peak current.
4. **Idle Time:** 100 msec to 10 sec.
5. **Direction Polarity:** Toggles direction polarity.
6. **One-clock or Two-clock mode:** One-clock or Two-clock mode.
7. **Over Temperature Shutdown:** Determines whether or not the ACE-SDX disables when the temperature rises above a specified threshold. See Figure 5.0 for details.
8. **Read:** Reads settings from the device and displays them.
9. **Write:** Writes the displayed settings to the device.
10. **Close:** Exit the configurator.

### 6.3. Default Settings

ACE-SDX product comes with following default factory settings.

Product	$\mu$ Step	Run Current (A)	Idle Current (A)	Idle Time (ms)	Dir	Clock
ACE-SDX	50	1.0	0.5	500	CW	One

Table 6.0

When setting the run and idle current, make sure to keep the current value below the maximum allowed current that each motor can handle.

## **Contact Information**

Arcus Technology, Inc.

3159 Independence Drive  
Livermore, CA 94551  
925-373-8800

[www.arcus-technology.com](http://www.arcus-technology.com)

The information in this document is believed to be accurate at the time of publication but is subject to change without notice.